

POOL COVER SPECIALISTS®

3 Wire Motor Limit Control Installation Instructions

Installation Notes:

1. Before working on any electrical equipment make sure the breaker has been shut off first.
2. If the Limit Control is ordered as parts of a motor assembly the control will be prewired to the motor.
3. Make sure the Limit Control Enclosure is mounted as high as possible in the cover box. Attach the enclosure using the provided mounting hardware.
4. The motor requires 8 amps and all wiring from the power supply to the motor must be sized accordingly.
5. Use a 15amp GFCI breaker at the panel.
6. 3 Wire Motor Limit Control was not designed to work with 5 wire motors.
7. The LED will indicate what direction the motor will run in when power is active on D1 or D2.

NOTE: Wires supplied by builders may not match colors provided, make sure to match the wires at each end.

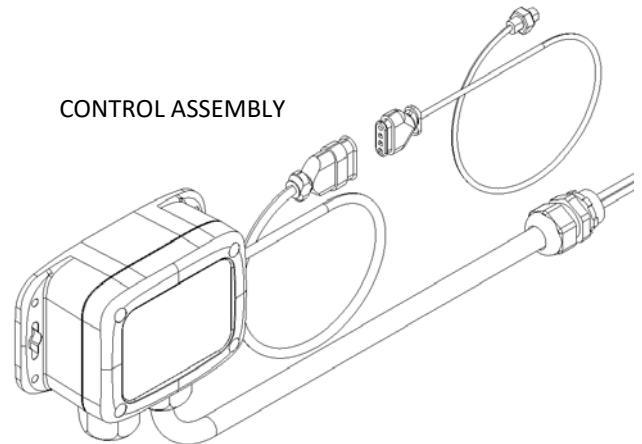

Motor Wiring Instructions:

1. Connect Motor Red to Control M2 (Run 2)
2. Connect Motor Black to Control M1 (Run 1)
3. Connect Motor White to Control N
4. Connect Switch Red to Control D1
5. Connect Switch Blue to Control D2
6. Connect Switch Black to Line 2 (Hot)
7. Connect Power Neutral to Control N
8. Connect Motor Green to Ground

Hall Effect Sensor Wiring Instructions:

1. Connect Sensor White to Control 5v+ (5 volts DC)
2. Connect Sensor Green to Control G- (0 volts DC or COMMON)
3. Connect Sensor Red to Control S1 (Sensor Output 1)
4. Connect Sensor Black to Control S2 (Sensor Output 2)
5. See Simplified Schematic for more information

Reed Switch Sensor Wiring Instructions:

1. Connect Sensor 1 Lead (Either Wire) to Control S1 (Sensor Output 1)
2. Connect Sensor 2 Lead (Either Wire) to Control S2 (Sensor Output 2)
3. Connect Both Sensor 1 & 2 Opposite Lead to Control G- (0 volts DC or Common)
4. See Technical Schematic for more information

Sensor Installation:

1. Run cover in the close direction.
2. While cover is running trigger sensor with magnet.
 - i) **Note for hall effect sensors:** If it doesn't stop flip magnet and try again (The Hall Effect Sensor is polarity sensitive). Make note of magnets direction.
 - ii) **Note for reed switches:** If it doesn't stop try switching the S1 and S2 leads. The sensor needs to be matched to run direction.
3. Finish closing the cover (you will need to reverse direction for a second to unlock the close direction).
4. When the cover is fully closed, make a small slit in the webbing at a point that will never run through the guide feeds (track guides).
5. Insert magnet into the cover's webbing through the slit. Make sure the magnet is facing the same direction it was in step 2 when it stopped the cover.
6. Position the magnet so it just starts to cover the sensor. Don't push it in to far, it is a lot easier to push the magnet further than it is to pull it back.
7. When the close magnet in place open the cover until it gets to a point you want the cover to stop. Do not go to far, there is not stop at this time for open.
8. Open the end of the webbing with a flat head screw driver and feed the magnet through the opening, make sure the magnet is facing the opposite direction from the one place in the close direction. You are not required to make a slit for the open sensor.
9. Position the magnet so it just sits over the sensor.
10. Run the cover in both directions and make sure the cover stops like it should. Make whatever adjustments are needed.

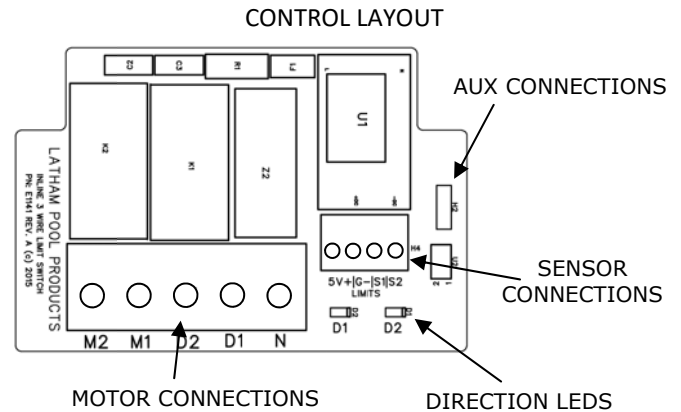

WIRING SCHEMATICS

WARNING: 220 POWER REQUIRES ALTERNATIVE RELAY. ONLY 110 IS SUPPORTED BY DEFAULT.

TOGGLE OR ROCKER

NOTE: The switch wires may be replaced with alternative colors depending on field wiring.

3 WIRE 110 VAC MOTOR

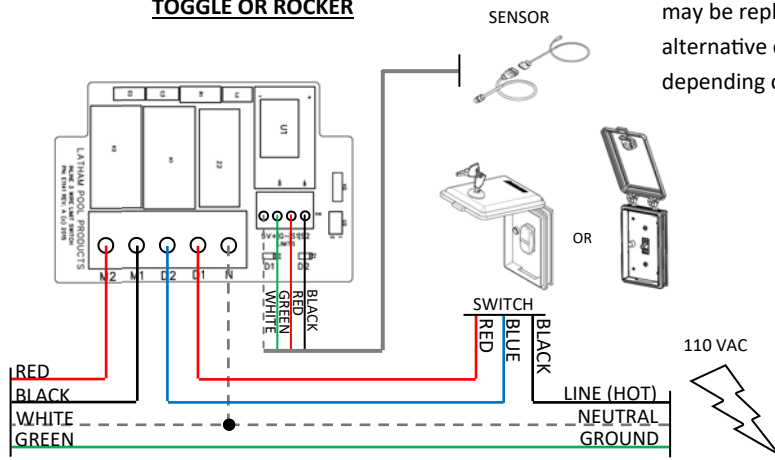
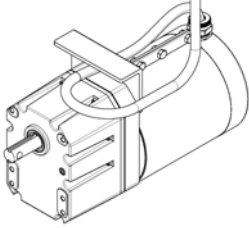

WARNING: 220 POWER REQUIRES ALTERNATIVE RELAY. ONLY 110 IS SUPPORTED BY DEFAULT.

KEYPAD

NOTE: The Keypad wires may be replaced with alternative colors depending on field wiring.

3 WIRE 110 VAC MOTOR

